

PITNEY BOWES QUICK GUIDETO USPS PRICES

New USPS prices take effect January 22, 2012.

First-Class Mail®

The shape and format of your mailpiece continue to have a significant impact on your cost. You can save \$0.003 for each letter that complies with the full-service Intelligent Mail® option requirements.

Select Rates for First-Class Mail®	Current	Jan '12
Single-piece Letter – First ounce	\$0.44	\$0.45
Single-piece Flat – First ounce	\$0.88	\$0.90
Single-piece Parcel – 1-3 oz.	\$1.71	\$1.95
Each additional ounce (letters and flats)	\$0.20	same
Each additional ounce (parcels)	\$0.17	same
Nonmachinable surcharge	\$0.20	same
Presorted Letter – First ounce	\$0.414	\$0.424
Presorted Flat – First ounce	\$0.757	\$0.762
Automation Letter – 5-digit – First ounce	\$0.340	\$0.350
Automation Flat – 5-digit – First ounce	\$0.373	\$0.400
Postcards	\$0.29	\$0.32

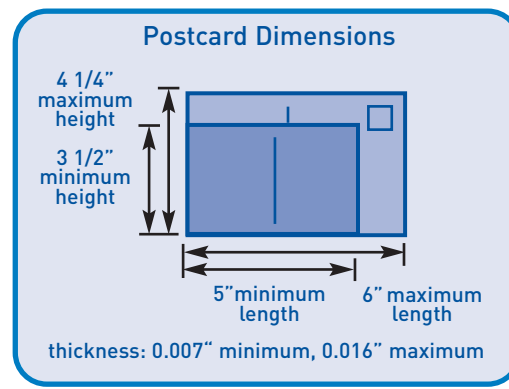

Standard Mail®

Continue to earn discounts for automation and NDC/SCF Destination Entry. Save \$0.001 on letters that comply with full-service Intelligent Mail® requirements.

Select Rates for Standard Mail®	Current	Jan '12
Letter no more than 3.3 oz. – AADC (Nonautomation)	\$0.260	\$0.265
Flat no more than 3.3 oz. – ADC (Nonautomation)	\$0.516	\$0.528
Letter no more than 3.3 oz. – 5-digit (Automation)	\$0.237	\$0.242
Flat no more than 3.3 oz. – 5-digit (Automation)	\$0.347	\$0.353
NDC Destination Entry Discount (Piece Rate)	\$0.033	same
SCF Destination Entry Discount (Piece Rate)	\$0.043	same

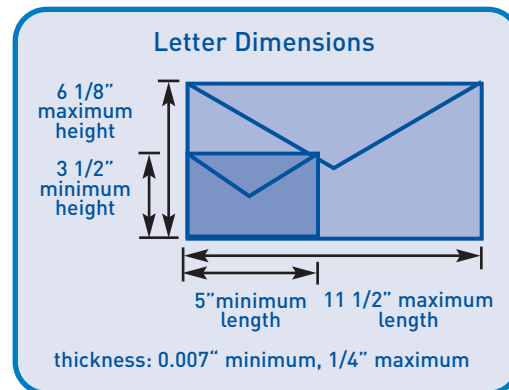

Priority Mail®, Express Mail® and Package Services

Business mailers who send mail using Priority Mail® or Express Mail® service may be eligible Commercial Pricing – discounts made easier with your Pitney Bowes digital mailing system.

Select Retail Rates for Priority Mail® Express Mail® and Package Services	Current	Jan '12
Priority Mail® – Flat Rate Envelope	\$4.95	\$5.15
Priority Mail® – Small Flat Rate Box	\$5.20	\$5.35
Priority Mail® – Medium Flat Rate Box	\$10.95	\$11.35
Priority Mail® – Large Flat Rate Box	\$14.95	\$15.45
Express Mail® – Flat Rate Envelope	\$18.30	\$18.95
Parcel Post – 1 lb. Zone 1 & 2	5.10	\$5.20
Media Mail – 1 lb. Single-Piece	\$2.41	\$2.47
Library Mail – 1 lb. Single-Piece	\$2.29	\$2.35

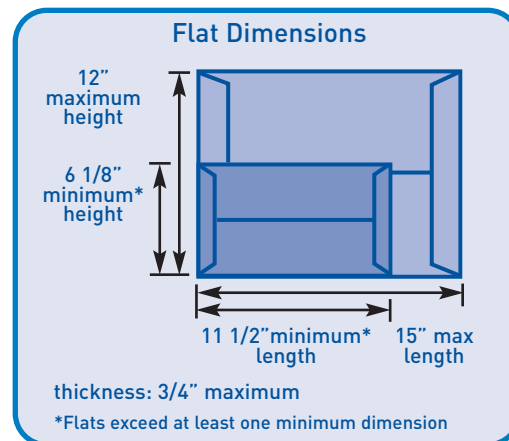

Extra Services

The USPS offers many services that can help you confirm delivery. Take a moment to understand your choices so you can select the best option for your business.

Select Rates for Extra Services	Current	Jan '12
Registered Mail™ Base Rate	\$10.75	\$10.95
Certified Mail™	\$2.85	\$2.95
Return Receipt (paper-based)	\$2.30	\$2.35
Electronic Return Receipt	\$1.15	same
First-Class Address Correction – Manual	\$0.50	same
First-Class Address Correction – Electronic	\$0.10	same

For more details, including new rate tables, please visit www.usps.com/prices.