



Shipping & Mailing
Inserter

Relay™ 1000

Document Inserting System

Quick Install Guide

International English Edition

SV63177 Rev. B

February 1, 2016

FCC Compliance

This equipment has been tested and found to comply with the limits for a Class A digital device, pursuant to part 15 of the FCC rules. These limits are designed to provide reasonable protection against interference when the equipment is operated in a commercial environment. This equipment generates, uses, and can radiate radio frequency energy and, if not installed and used in accordance with the instruction manual, may cause interference to radio communications. Operation of this equipment in a residential area is likely to cause interference, in which case the user will be required to correct the interference at his own expense. Use only a shielded interface cable to operate this equipment with a printer or other peripheral device.

CAUTION: Changes or modifications to this equipment not expressly approved by the party responsible for compliance (Pitney Bowes) could void the user's authority to operate the equipment.



It is certified that this system complies with all applicable Directives of the European Union.

SV63177 Rev. B February 1, 2016

©2005, 2016 Pitney Bowes Inc. All rights reserved. This guide may not be reproduced in whole or in part in any fashion or stored in a retrieval system of any type or transmitted by any means, electronically or mechanically, without the express, written permission of Pitney Bowes.

We have made every reasonable effort to ensure the accuracy and usefulness of this manual; however, we cannot assume responsibility for errors or omissions or liability for the misuse or misapplication of our products.

Due to our continuing program of product improvement, equipment and material specifications as well as performance features are subject to change without notice. Your inserter system may not have some of the features described in this book.

E-Z Seal is a registered trademark of Pitney Bowes Inc. ENERGY STAR is a registered trademark of the United States Environmental Protection Agency.

Relay 1000 Quick Install Guide

Follow the instructions in this guide to get your Relay 1000 system setup and running in the shortest possible time. Included in this guide are instruction for the following:

- Unpack
- Set in place
- Connect
- Fill the moistener
- Load envelopes
- Load sheets
- Setup
- Run a test piece

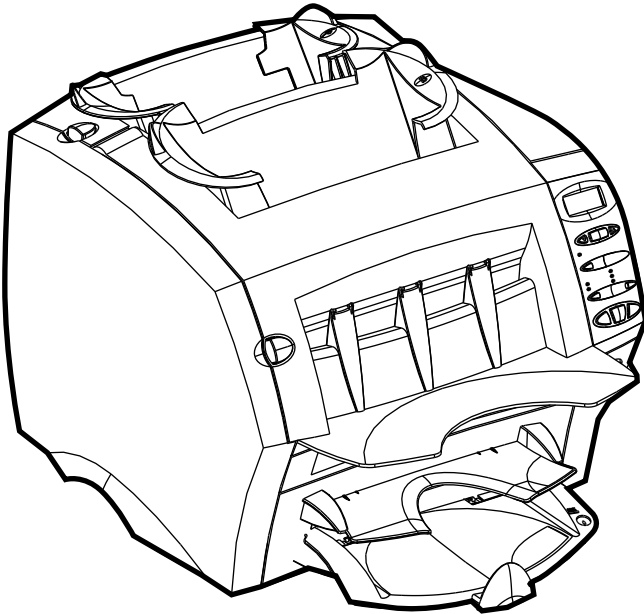

IMPORTANT: If you purchased the optional second sheet feeder, unpack it and position it on the desktop *BEFORE* you follow these instructions.

Step 1: Unpack

1. Lift out the following accessories and put them to one side:
 - Test paper and envelopes
 - Bottle of E-Z seal®
 - Power Cord

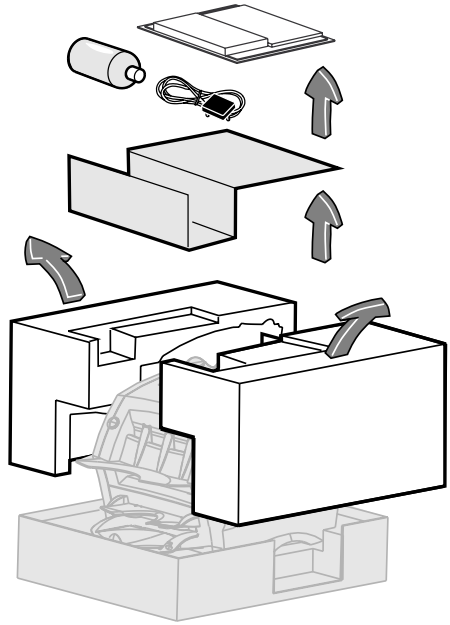

2. Remove the cardboard and foam packing.

Step 2: Set in Place

1. Lift the inserter by its handles and place it on a flat surface.

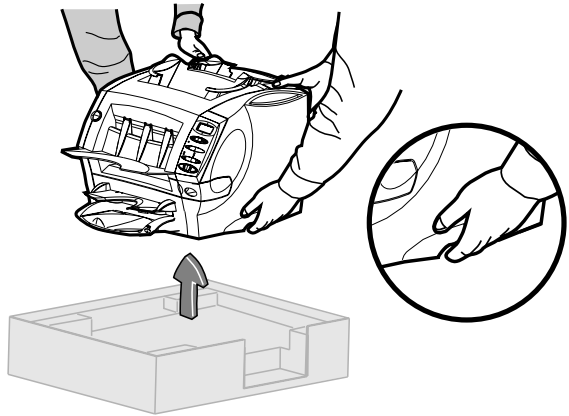

SAFETY NOTICE!

- Lift the inserter *only* by its lifting handles.
- Lift correctly (bend knees and keep back straight).
- The inserter weighs about 38 lb (17.5 kg). It is recommended you get help to lift it.

2. If you have the optional 2nd sheet feeder, position the inserter onto that feeder now.

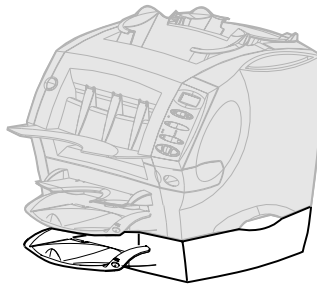

Step 3: Connect and Turn On

1. Connect the power cord.

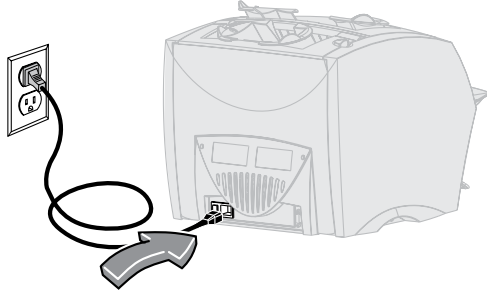

2. Switch the power ON. *(The power switch is on the back panel next to the power cord.)* After a few seconds, the display shows **READY**.

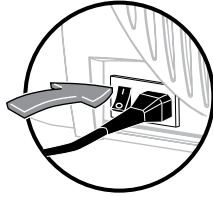

SAFETY NOTICE!

- Locate the system close to a power socket.
- Use the power cord supplied.
- See the Relay 1000 Operating Guide for complete safety and connection information.

Step 4: Fill the Moistener

1. Slide the moistener open.

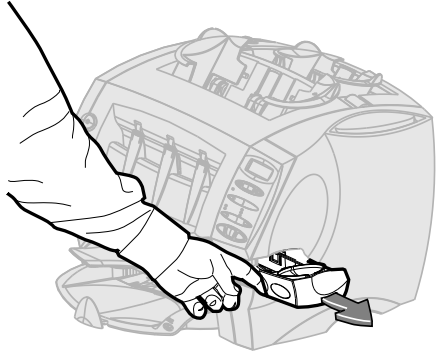

2. Fill the moistener with E-Z Seal®. Use the entire bottle.

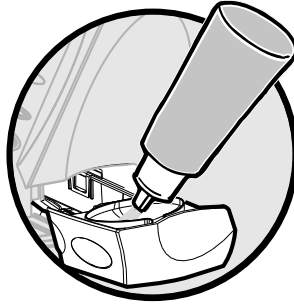

3. Slide moistener closed.

NOTE: The moistener takes about five minutes to become fully wet and ready for use. During this process, you can continue setting up.

Step 5: Load Envelopes

Use the test paper and envelopes to practice using the system and to make sure that system is working correctly.

1. Fan test envelopes marked with the letter B.
2. Tap the stack of envelopes to align edges.
3. Place envelopes in feeder B - RIGHT WAY UP and FACING YOU.
4. Use blue handles at the rear of the guides to move them. Slide the side guides until they just touch the envelopes.
 - If guides are *too tight*, envelopes may stall.
 - If they are *too loose*, envelopes may skew.

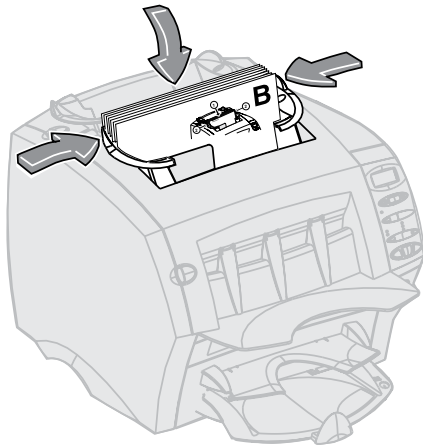
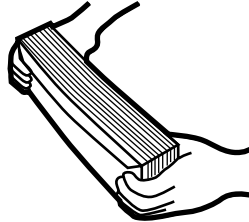

Step 6: Load Sheets

1. Fan the stack of sheets test sheets that are marked with A1.
2. Tap the stack to align the edges.

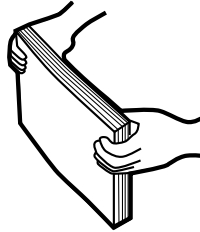

3. Place the stack of sheets in feeder A1, FACE DOWN and BOTTOM EDGE FIRST.
4. Push the backstop in until it just touches the stack of sheets.

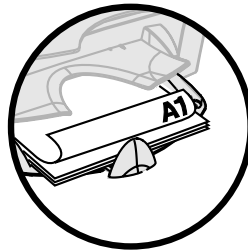

IMPORTANT:

- Always fan (aerate) sheets before loading.
- Always load sheets FACE DOWN and BOTTOM EDGE FIRST.

Step 7: Setup

A green indicator on the control panel shows that a feeder or function is selected. Pressing the selection buttons repeatedly (a, b, and c in the image below) steps through feeders and options available on your system.

To set up the system:

1. Press the **Feeder A1 (a)** button until the associated Feeder A1 LED turns green.
2. Press the **Envelope Feeder B (b)** button until the associated **Envelope Fdr B** LED turns green.
3. Press the **Seal (c)** button until the associated **Seal** LED turns green.

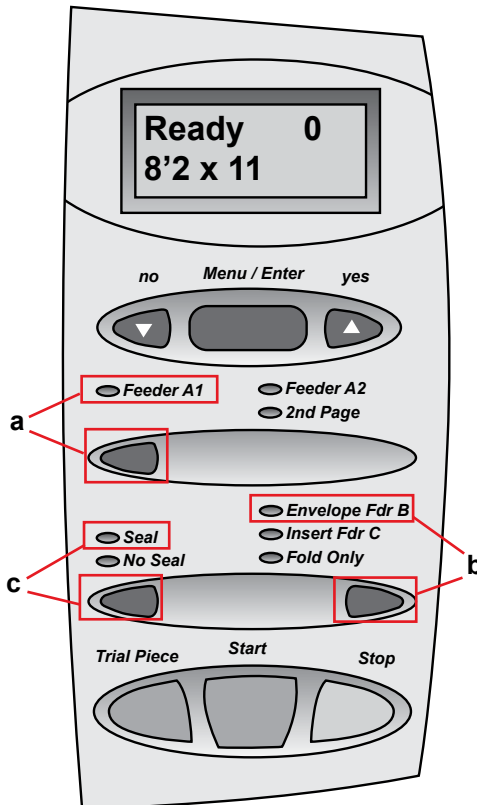

Step 8: Run a Test Job

To run a test job:

1. Press the **Trial Piece** button.
2. If the trial piece checks out ok, press **Start**.
3. Press **Stop** to stop processing.

NOTE: The trial piece will not be sealed so you can check the contents of the envelope. This is normal. The counter will show the number of items processed.



Step 9: Congratulations

Your Relay 1000 is now ready to use. There is a slot on the the top right side of the cover (shown in the image below) for storage of the Relay 1000 Operator Guide. This guide explains how to use your new system.

If you experience any problems installing your equipment, please refer to the *Troubleshooting* section in the Operating Guide.

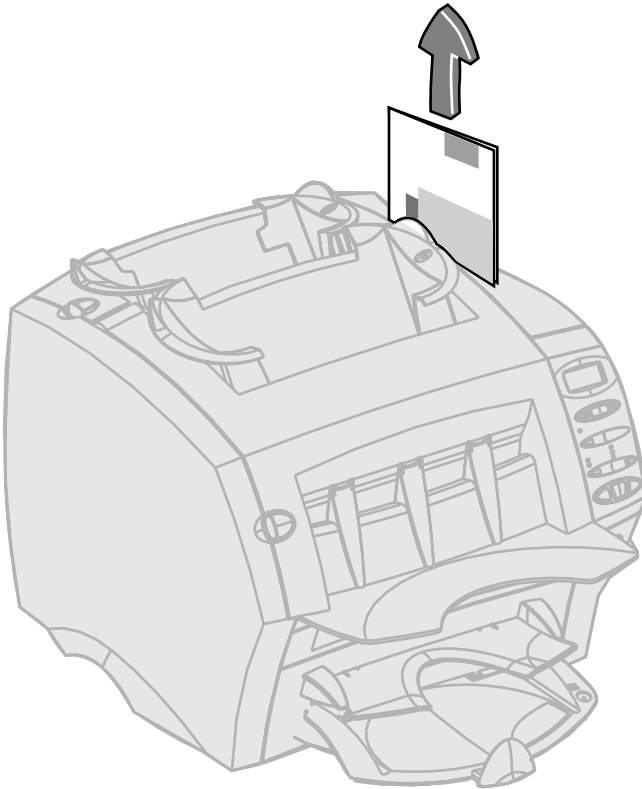

This page intentionally blank.

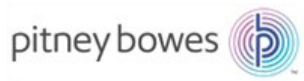

3001 Summer Street
Stamford, CT 06926-0700
www.pitneybowes.com

SV63177 RevB
©2016 Pitney Bowes Inc.
All Rights Reserved